

ALPHA meter relay option board retrofit kit

Installation instructions
IL42-4003D

General

This leaflet contains instructions for installing relay option boards on ALPHA® electronic meters. This option provides contact closures representing energy usage and interval timing. It is available with 1, 2, or 6 relays. A complete description of the relay option board is included in your technical manual or other documentation for your meter.

Unpacking the retrofit kit

 **CAUTION**

The ALPHA electronic meter and option boards contain components that are sensitive to electrostatic discharge (ESD). When installing, servicing, or removing the ALPHA meter or any option board, connect to ground with a wrist strap and follow safe ESD procedures. Failure to properly ground both you and the electronic devices or follow safe ESD procedures to avoid ESD can result in equipment damage.

- 1 Carefully unpack all kit parts. Each kit should include the following:
 - 1 printed circuit board assembly
 - 1 cable and connector assembly (either 6 or 12 conductors, depending on board style)
 - 3 plastic printed circuit board mounting posts
- 2 Visually inspect all parts for shipping damage.

Exiting the relay cable from the meter base

⚠ WARNING

Do not disassemble the meter chassis or electronic assembly from the meter chassis with power present. This may expose you to dangerous voltages, resulting in equipment damage, personal injury, or death.

The meter base must be prepared so that the relay cable can exit the hole in the base.

- 1 Remove the meter cover.
- 2 Remove the electronic assembly from the base housing by rotating the electronic assembly counterclockwise while holding the base housing stationary.
- 3 Locate the knockout for the cable exit in the meter base. The words "Option Cable" or "Option Cable 1" are molded in the housing just above the knockout.
- 4 Punch out the knockout in the meter base and remove any material remaining in the hole.
- 5 Feed the relay option cable through the hole in the base with the connector to the inside.
- 6 Pull the cable from the outside and force the cable grommet to seal the hole in the base.

Attaching the relay cable to the meter blades

⚠ WARNING

Before continuing, you must make sure there are no voltage source connected to any relay option leads or to the meter in order to avoid exposure to dangerous voltages which may result in personal injury or death.

Use the following procedure to attach the relay cable to the meter voltage blades.

- 1 Remove the meter cover.
- 2 Remove the electronic assembly from the base housing by rotating the electronic assembly counterclockwise while holding the base housing stationary.
- 3 Disconnect the current and voltage cables from the ALPHA meter board in the electronic assembly. Set the electronic assembly aside.
- 4 Remove the 3 screws attaching the base housing to the base and set the housing aside.
- 5 Connect the relay cable to the KYZ output blades in the base by pushing the appropriate wire's connector onto the tab attached to the blade. Looking at the base from the front of the meter, the left-most voltage blade is number 1 and the right-most blade is number 7.
 - For Form 6S meters, connect K (red), Y (yellow), and Z (black) leads to blades 3, 4, and 5 respectively.
 - For Form 9S meters, connect the K, Y, and Z leads to blades 4, 5, and 6 respectively.
- 6 Route the relay cable through the voltage opening in the housing and reassemble the base housing to the base using care to avoid pinching the cables between the two parts.

Mounting the relay option board

⚠ WARNING

Before continuing, you must make sure there are no voltage source connected to any relay option leads or to the meter to avoid exposure to dangerous voltages which may result in personal injury or death.

Use the following procedure to mount the relay option board at position 1 (see Figure 2) or position 2 (see Figure 3). Note that the procedure is the same regardless of meter or the option board that may be installed at position 1.

- 1 Position the meter so that the electronic assembly faces down.
 - 2 Insert the plastic mounting posts into the proper holes in the ALPHA meter board.
- Note: Be sure the jumper is in the correct position. Figure 1 shows the correct jumper location for use with the ALPHA Plus® and A3 ALPHA meters.
- 3 Plug the relay option cable connector (J6) into P6 on the relay board. Make certain that the polarizing tabs on the connector align with notches on the ends of P6 and that the cable leads exit from the bottom of J6, toward the ALPHA meter board.
 - 4 Align the relay option board as appropriate for mounting in either position 1 or position 2:
 - Position 1: align P4 on the relay option board with J4 on the ALPHA meter board and align the holes with the mounting posts.
 - Position 2: align J5 on the relay option board at position 2 with P5 on the option board at position 1 and align the holes with the mounting posts.
 - 5 Gently press down on the relay board until the mounting posts snap into the holes in the relay board to ensure a lock fit.

Figure 1. Location of jumper for use with ALPHA Plus or A3 ALPHA meters

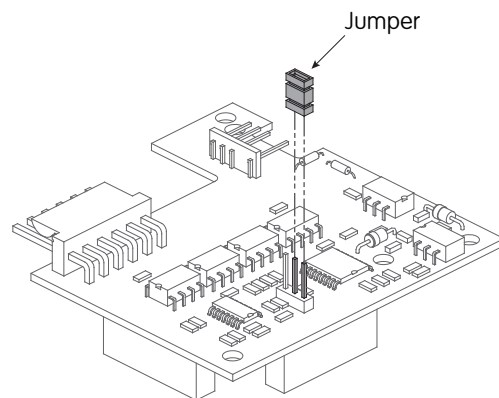

Figure 2. Mounting the relay option board at position 1

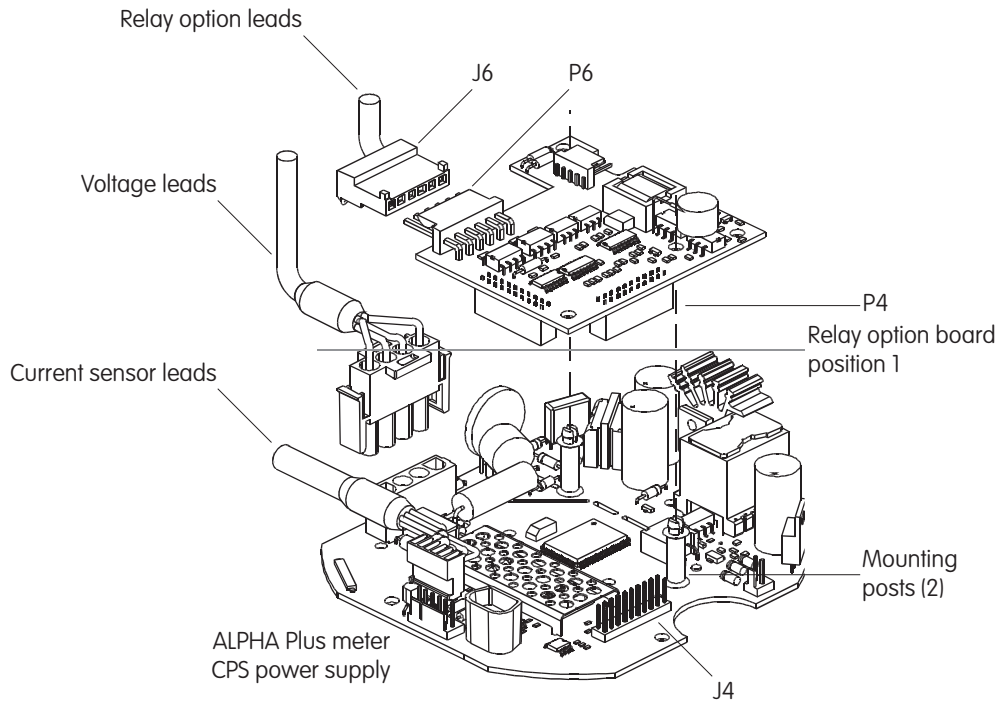
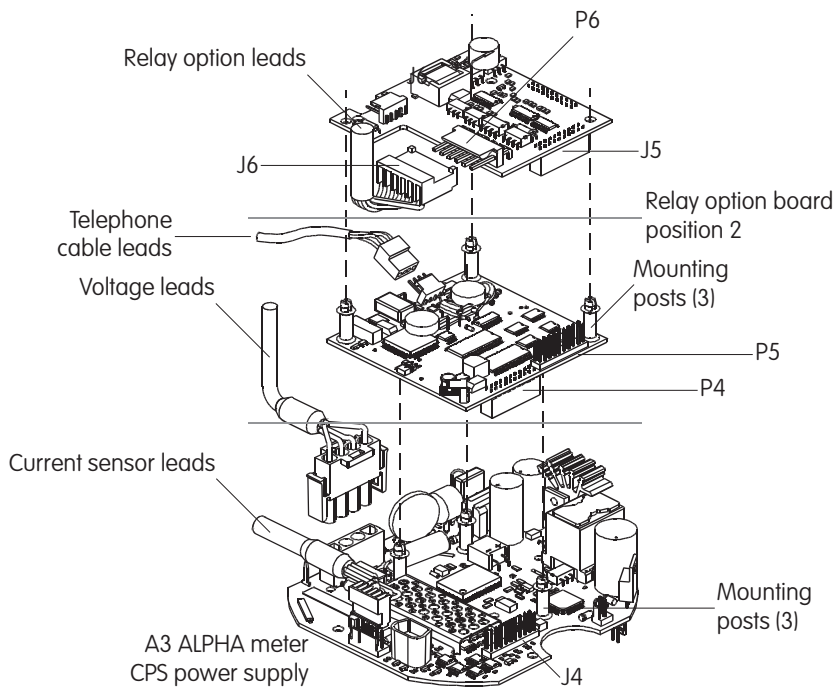

Figure 3. Mounting the relay option board at position 2



Reassembling the meter

After mounting the relay option board, use the following procedure to assemble the meter.

- 1 If still wearing, remove the wrist strap before proceeding with reassembling the meter.
- 2 Reconnect the current and voltage connectors from the base housing to the electronic assembly. Note that the connectors are keyed for proper orientation.
- 3 Align the top of the electronic assembly with the section of the base housing where the word "TOP" is molded into the plastic.
- 4 Reassemble the electronic assembly to the base housing by rotating the electronic assembly clockwise. Use care to avoid pinching cables or placing strain on the circuit boards.
- 5 Replace the meter cover.

Figure 4. Relay output wiring (1 or 2 relays)

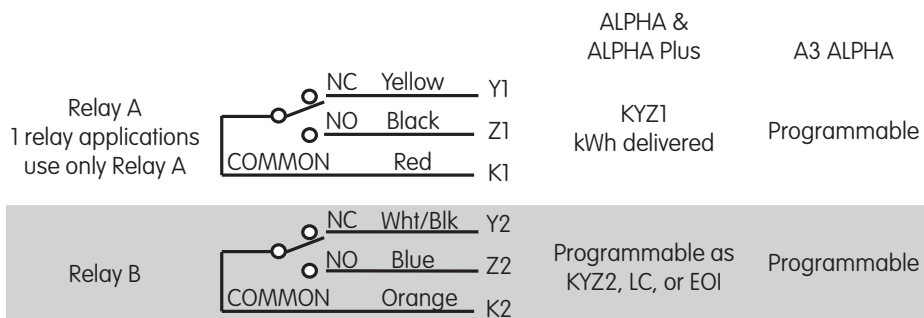
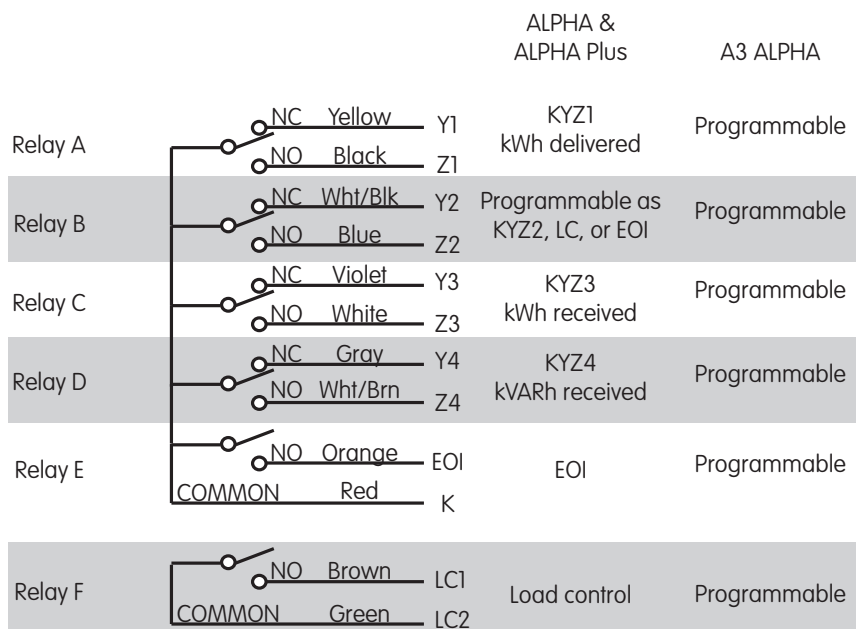

Figure 5. Relay output wiring (6 relays)



Notes:

DISCLAIMER OF WARRANTIES AND LIMITATIONS OF LIABILITY

There are no understandings, agreements, representations, or warranties either express or implied, including warranties of merchantability or fitness for a particular purpose, other than those specifically set out by any existing contract between the parties. Any such contract states the entire obligation of the seller. The contents of this document shall not become part of or modify any prior existing agreement, commitment, or relationship.

The information, recommendations, descriptions, and safety notices in this document are based on Elster Solutions, LLC experience and judgment with respect to operation and maintenance of the described product. This information should not be considered as all-inclusive or covering all contingencies. If further information is required, Elster Solutions, LLC should be consulted.

No warranties, either expressed or implied, including warranties of fitness for a particular purpose or merchantability, or warranties arising from the course of dealing or usage of trade, are made regarding the information, recommendations, descriptions, warnings, and cautions contained herein.

In no event will Elster Solutions, LLC be responsible to the user in contract, in tort (including negligence), strict liability or otherwise for any special, indirect, incidental, or consequential damage or loss whatsoever, including but not limited to: damage or loss of use of equipment, cost of capital, loss of profits or revenues, or claims against the user by its customers resulting from the use of the information, recommendations, descriptions, and safety notices contained herein.