

A3 ALPHA meter with wireless 3G cellular communications

IL42-4042C

General

This leaflet provides general information for the Wireless WIC communication option for the A3 ALPHA meter. For information on installing the A3 ALPHA meter, see the "ALPHA Meter Installation Instructions" (IL42-4001Q or later).

The A3 ALPHA meter may be ordered with a wireless cellular communication option: the Wireless WAN Interface Card (Wireless WIC). The Wireless WIC is available in CDMA 1xRTT/1xEV-DO and UMTS/HSPA+ versions, providing a high speed, 3G cellular communication channel for the meter. Additional hardware configurations may include either a relay option board or an interrupter control board for standard ALPHA meters.

The A3 ALPHA meter with Wireless WIC communication may be ordered in the following configurations:

Description	Model number ¹
A3 ALPHA meter, CDMA 1xRTT/1xEV-DO, internal WAN antenna Additional options: relay option board or interrupter control board	A3WWIC3_EV_
A3 ALPHA meter, CDMA 1xRTT/1xEV-DO, external WAN antenna Additional options: relay option board or interrupter control board	A3WWIC3_EVX_
A3 ALPHA meter, UMTS/HSPA+, external WAN antenna Additional options: relay option board or interrupter control board	A3WWIC3_UXA
A3 ALPHA meter, UMTS/HSPA+, internal WAN antenna Additional options: relay option board or interrupter control board	A3WWIC3_UA
A3 ALPHA meter with gatekeeper module, EVDO, internal WAN antenna, internal LAN antenna	EA_GKWWIC3_EV_
A3 ALPHA meter with gatekeeper module, EVDO, external WAN antenna, internal LAN antenna	EA_GKWWIC3_EVX_
A3 ALPHA meter with gatekeeper module, UMTS/HSPA+, external WAN antenna, internal LAN antenna	EA_GKWWIC3_UXA

¹For CDMA/EVDO, the last character in the model number is carrier dependent.

⚠ WARNING

Use authorized utility procedures to install and service metering equipment. Dangerous voltages are present. Equipment damage, personal injury, or death can result if safety precautions are not followed.

Use circuit closing devices on current transformer secondaries (3S, 4S, 5S, 5A, 6S, 6A, 8S, 9S, 10S, 10A, 26S, 29S, 35S, 36S, and 36A meters). Equipment damage, personal injury, or death can result if circuit closing secondaries are not used.

Location of antennas

See Figure 1 for the location of the Wireless WIC internal antenna.

The Wireless WIC internal antenna is fix-mounted to the periphery of the A3 ALPHA meter's electronic housing. The Wireless WIC antenna is not adjustable or removable.

Alternatively, A3 ALPHA meters may be ordered with an external WIC antenna. With this option, the meter is shipped with an RF "pigtail" output cable which allows connection to a multi-band cellular antenna external to the meter. This is advantageous in locations with lower cellular signal strength. Also, certain Wireless WIC configurations (for example, UMTS/HSPA+) are presently only available with an external WIC antenna.

See Figure 2 for the recommended location of the Wireless WIC external antenna. Elster recommends mounting the external Wireless WIC cellular antenna on the top of the meter socket box as shown, centered in the available space on the meter box's top surface.

- Drill and/or punch the specified antenna mounting hole in the top of the meter socket box and install the antenna using the antenna manufacturer's instructions.
- Connect the meter's RF "pigtail" output cable directly to the antenna via its integral N-type connector. The Wireless WIC antenna output cable may be ordered in two lengths: 19 or 36 inches. Choose the length based on the distance from the meter to the Wireless WIC external antenna, which is in turn determined by the size of the meter socket box.

NOTICE

Please note that external cellular antennas must be purchased separately, either from Elster or a third party, from a list of approved antennas. Please ask your Elster Sales Representative for the current list of approved external cellular antennas.

⚠ WARNING

Use approved utility safety procedures while installing the external antenna and meter RF output cable in the meter socket box. Dangerous voltages may be present. Assure that there is sufficient clearance between any line-energized socket part and the exposed metal of the antenna connectors. Also assure that the external antenna is electrically bonded to the meter socket box. Failing to follow approved utility safety procedures, failing to allow sufficient clearance, or failing to electrically bond the external antenna to the meter socket box may result in equipment damage, personal injury, or death.

Figure 1. Location of internal antennas

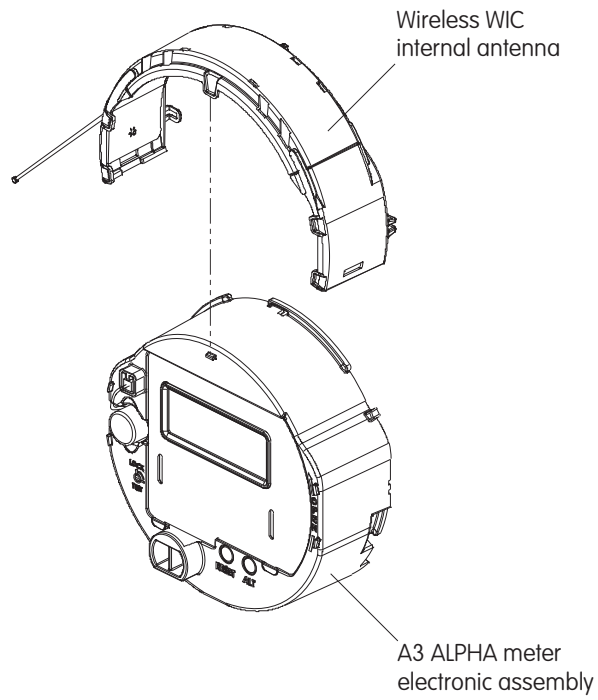
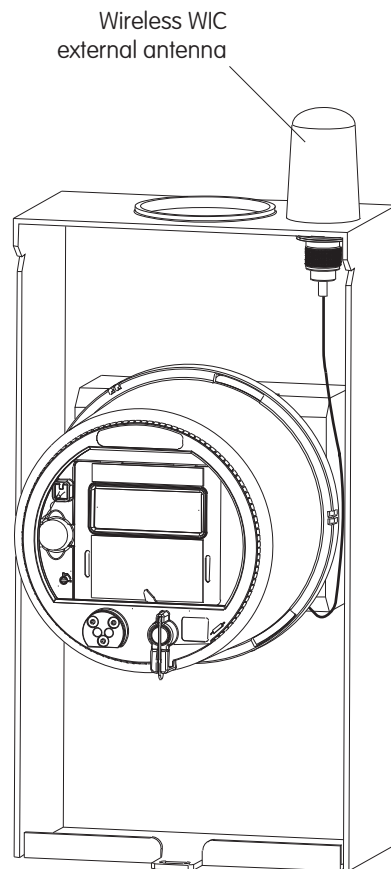

Figure 2. Location of Wireless WIC external antenna



Placing the A3 ALPHA meter with Wireless WIC into service

⚠ WARNING

Use authorized utility procedures when placing the standard A3 ALPHA meter into service. Equipment damage, personal injury, or death can result if authorized utility procedures are not followed.

See IL42-4001Q or later for the A3 ALPHA meter installation instructions. When planning the meter installation, consider the following additional guidelines:

- Since the Wireless WIC and EA_LAN (if present) are high frequency communication devices, site the meter so that the front of the meter has the best possible view of the surrounding terrain.
- Do not place metal structures (other than the meter socket and related cabling) within 20 cm of the meter.

After the Wireless WIC external antenna is installed (if supplied) and the A3 ALPHA meter is installed and powered as instructed in IL42-4001Q or later, the installation is complete. To verify operation of the Wireless WIC on-site, the following steps may be taken:

- 1 After installing and powering the A3 ALPHA meter, wait approximately 5 minutes for the Wireless WIC to connect to the cellular network and initialize.
- 2 Using Metercat and an optical probe connection, perform a diagnostic read. For information on using Metercat and performing diagnostic reads, see the Metercat software documentation or online Help.
- 3 Once the diagnostic read is performed, select the Special Option Board section. Several operational parameters are provided, including the following:

Item	Expected status
WAN wireless status	
Status	"Connected" means that the W-WIC is registered to a wireless network
Received Signal Strength Indicator	The RSSI may vary between 0 and 31, with 31 indicating the best possible signal strength. An RSSI value of 99 indicates an unknown or non-detectable signal.
WAN IP address	The IP address provided by the cellular network.

FCC Compliance

Important

The A3 ALPHA meter equipped with the Wireless WIC option complies with Part 15 of the FCC Rules. Changes or modifications not expressly approved by Elster could void the user's authority to operate the equipment.

FCC & IC Information

For CDMA 1xRTT/1xEV-DO versions of the A3 ALPHA meter with EA_Gatekeeper module and the Wireless WIC option:

- FCC ID: QZCWWIC3EV
- IC: 4557A-WWIC3EV

For UMTS/HSPA+ versions of the A3 ALPHA meter with EA_Gatekeeper module and the Wireless WIC option:

- FCC ID: QZCWWIC3U
- IC: 4557A-WWIC3U

For CDMA 1xRTT/1xEV-DO versions of the standard A3 ALPHA meter with the Wireless WIC option:

- FCC ID: RI7DE910-DUAL
- IC: 5131A-DE910DUAL

For UMTS/HSPA+ versions of the standard A3 ALPHA meter with the Wireless WIC option:

- FCC ID: RI7HE910NA
- IC: 5131A-HE910NA

Compliance Statement

This device complies with Part 15 of the FCC Rules and Class B digital apparatus requirements for ICES-003. Operation is subject to the following two conditions: (1) This device may not cause harmful interference, and (2) this device must accept any interference received, including interference that may cause undesired operation of the device.

Énoncé de conformité

Cet appareil est conforme à la Partie 15 des règles de la FCC et aux exigences relatives aux appareils numériques de classe B conformément à l'avis sur la compatibilité électromagnétique ACEM-3. L'utilisation de cet appareil est soumise aux deux conditions suivantes : (1) Cet appareil ne doit pas provoquer d'interférences nocives et (2) cet appareil doit accepter toutes les interférences reçues notamment celles pouvant provoquer un fonctionnement intempestif de l'appareil.

Note

This equipment has been tested and found to comply with the limits for a Class B digital device, pursuant to Part 15 of the FCC Rules and ICES-003. These limits are designed to provide reasonable protection against harmful interference in a residential installation. This equipment generates, uses and can radiate radio frequency energy and, if not installed and used in accordance with the instructions, may cause harmful interference to radio communications. However, there is no guarantee that interference will not occur in a particular installation. If this equipment does cause harmful interference to radio or television reception, which can be determined by turning the equipment off and on, the user is encouraged to try to correct the interference by one or more of the following measures:

- reorient or relocate the receiving antenna
- increase the separation between the equipment and the receiver
- connect the equipment into an outlet on a circuit different from that to which the receiver is connected
- consult the dealer or an experienced radio/TV technician for help

If you experience trouble with this equipment, please use the Return Material Authorization (RMA) feature available from the customer support section of www.elstersolutions.com. Do not attempt to repair this equipment yourself.

Caution

The antennas used for these transmitters must be installed to provide a separation of at least 20 cm from all persons and must not be collocated or operated in conjunction with any other antenna or transmitter except as documented in the FCC application. Users and installers must be provided with antenna installation instructions and transmitter operating conditions for satisfying RF exposure compliance.

Notes:

DISCLAIMER OF WARRANTIES AND LIMITATIONS OF LIABILITY

There are no understandings, agreements, representations, or warranties either express or implied, including warranties of merchantability or fitness for a particular purpose, other than those specifically set out by any existing contract between the parties. Any such contract states the entire obligation of the seller. The contents of this document shall not become part of or modify any prior existing agreement, commitment, or relationship.

The information, recommendations, descriptions, and safety notices in this document are based on Elster Solutions, LLC experience and judgment with respect to operation and maintenance of the described product. This information should not be considered as all-inclusive or covering all contingencies. If further information is required, Elster Solutions, LLC should be consulted.

No warranties, either expressed or implied, including warranties of fitness for a particular purpose or merchantability, or warranties arising from the course of dealing or usage of trade, are made regarding the information, recommendations, descriptions, warnings, and cautions contained herein.

In no event will Elster Solutions, LLC be responsible to the user in contract, in tort (including negligence), strict liability or otherwise for any special, indirect, incidental, or consequential damage or loss whatsoever, including but not limited to: damage or loss of use of equipment, cost of capital, loss of profits or revenues, or claims against the user by its customers resulting from the use of the information, recommendations, descriptions, and safety notices contained herein.

© 2015 by Elster. All rights reserved. Produced in the United States.